

HENRY ENGINEERING LOGICONVERTER

Remote Control for Multiple Satellite Receivers by Pristine RapidFire
 Prepared by Professional Management Services, Inc.

May 27, 2000

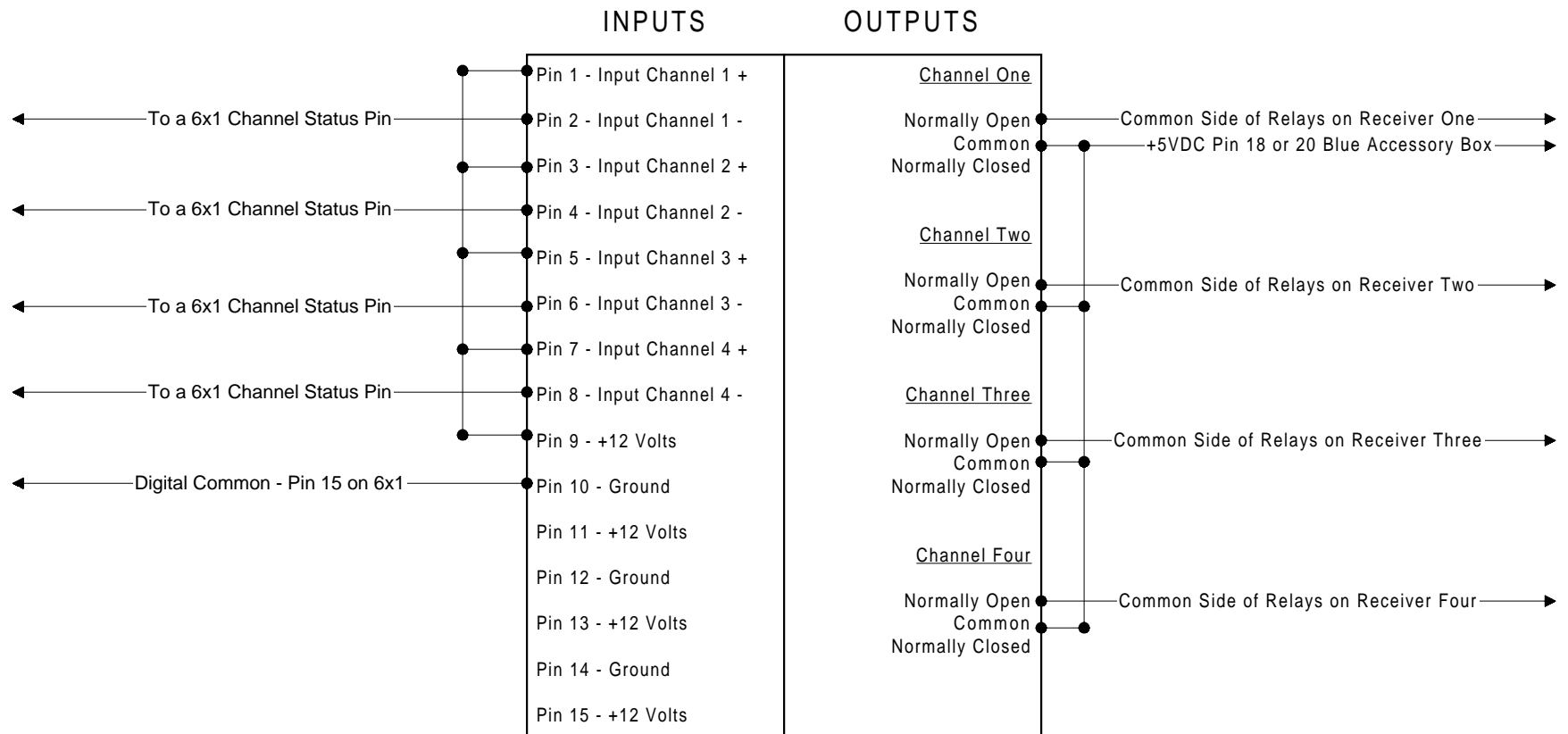

NOTES ON LOGICONVERTER:

- Inputs to Logiconverter are via female DB15 connector.
- Outputs from Logiconverter are via screw type barrier strip.
- Internal Logiconverter Dip Switch must be set as follows:

1,2 - OFF 3,4 - ON
 5,6 - OFF 7,8 - ON

PURPOSE OF USING LOGICONVERTER WITH 6X1 AUDIO SWITCH:

Use the Status Light on 6x1 Audio Switch Channels to latch +5VDC Remote Control Voltage to correct Satellite Receiver. RapidFire will remotely turn correct 6x1 Channel on and off via relay closures as determined by the Playlist.

NOTES ON 6X1 AUDIO SWITCHER:

- Remote Control Inputs are via female DB15 Connector.
- Audio Output are via removeable screw type connector.
- Pinouts for Remote Control and Status are:

1 - Switch Number 1	9 - Status Number 3
2 - Switch Number 2	10 - Status Number 4
3 - Switch Number 3	11 - Status Number 5
4 - Switch Number 4	12 - Status Number 6
5 - Switch Number 5	13 - Mute Audio Input
6 - Switch Number 6	14 - Step Input
7 - Status Number 1	15 - Digital Ground
8 - Status Number 2	